

Oct. 12, 1954

E. G. BAILEY ET AL

2,691,455

LOCOMOTIVE TENDER WITH MATERIAL HANDLING EQUIPMENT

Filed April 8, 1949

2 Sheets-Sheet 1

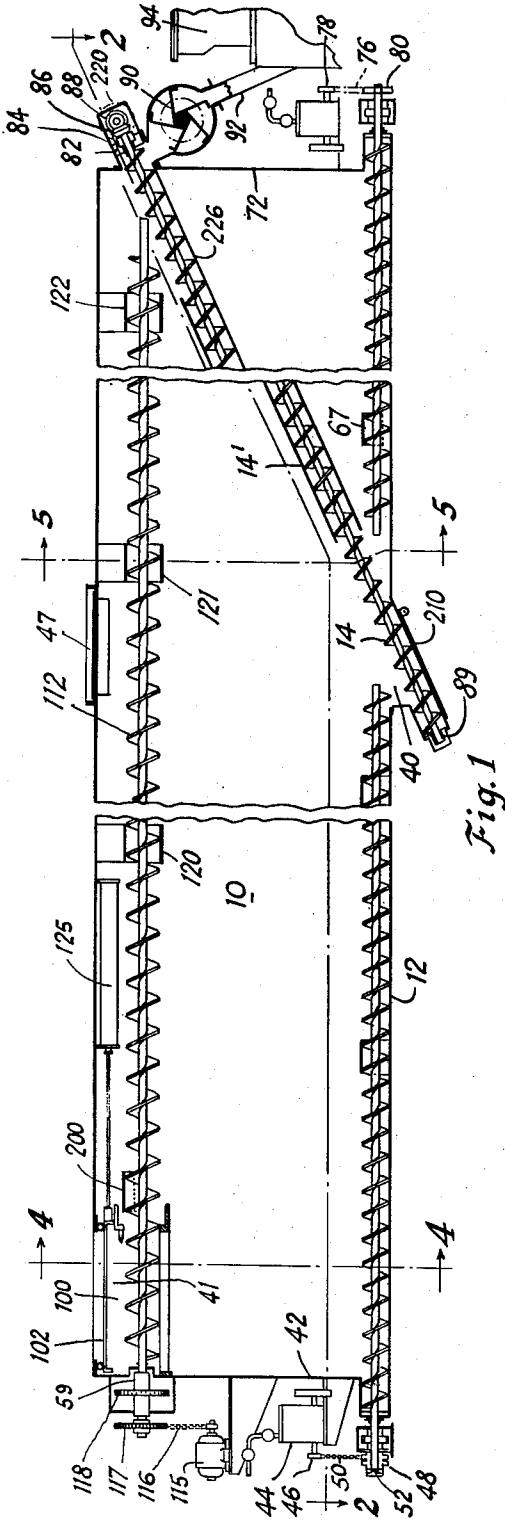

Fig. 1

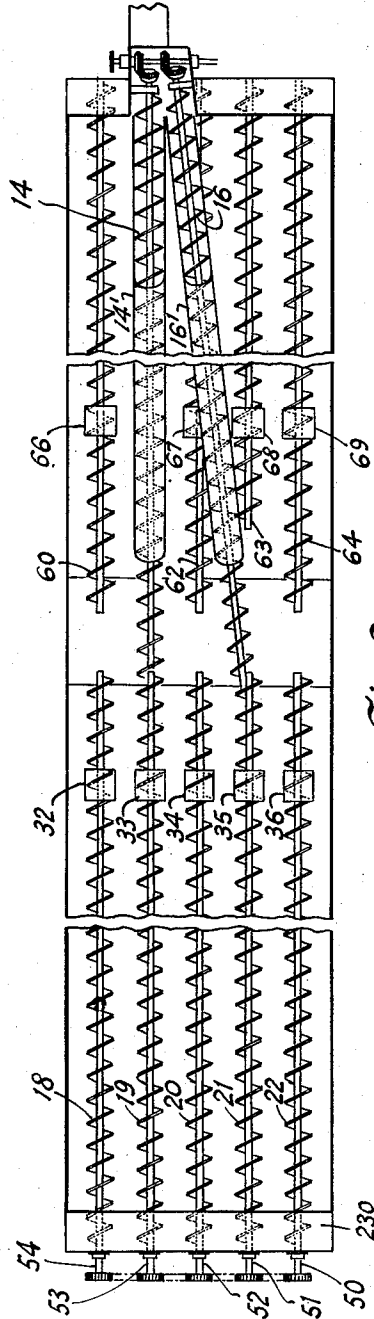

Fig. 2

INVENTORS  
 Ervin G. Bailey &  
 BY Ralph M. Hardgrove

*M. Hollbrook* ATTORNEY

Oct. 12, 1954

E. G. BAILEY ET AL

2,691,455

LOCOMOTIVE TENDER WITH MATERIAL HANDLING EQUIPMENT

Filed April 8, 1949

2 Sheets-Sheet 2

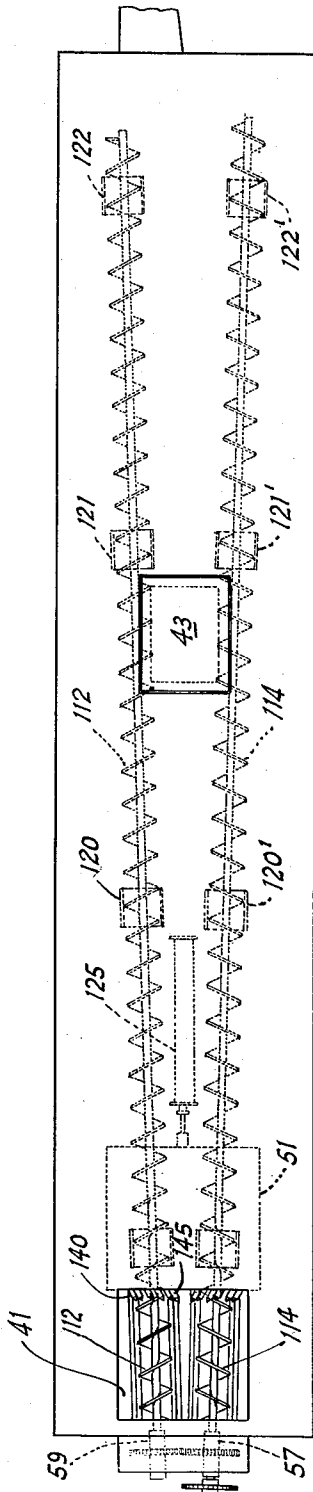

Fig. 3

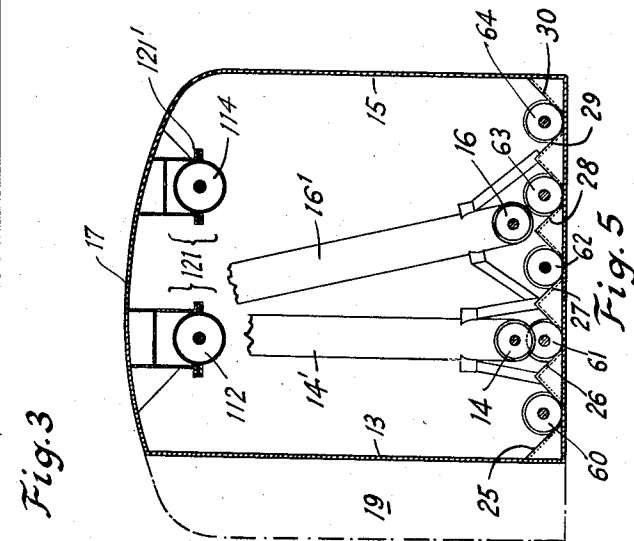

Fig. 5

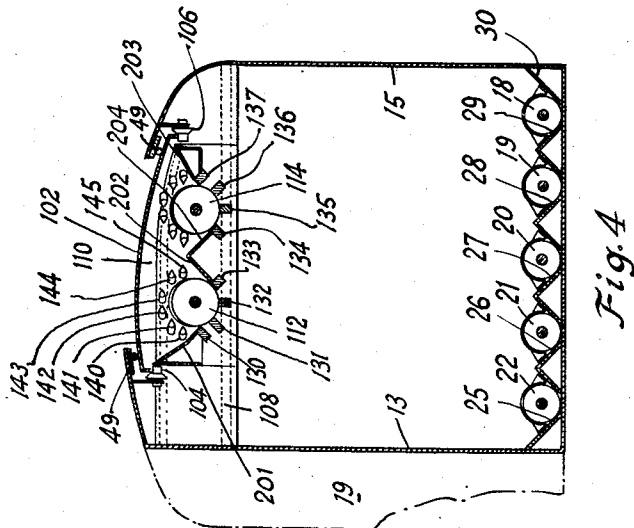

Fig. 4

INVENTORS  
Ervin G. Bailey &  
BY Ralph M. Hardgrove

M. Halbrook ATTORNEY

# UNITED STATES PATENT OFFICE

2,691,455

## LOCOMOTIVE TENDER WITH MATERIAL HANDLING EQUIPMENT

Ervin G. Bailey, Easton, Pa., and Ralph M. Hardgrove, Canton, Ohio, assignors to The Babcock & Wilcox Company, New York, N. Y., a corporation of New Jersey

Application April 8, 1949, Serial No. 86,173

5 Claims. (Cl. 214—519)

1

This invention relates to material handling devices and more particularly to a coal handling installation involving a bin associated in a particular manner with a coal feeder.

This case is particularly concerned with a coal tank for a locomotive tender which advantageously uses the maximum available cross sectional available space and provides auxiliary apparatus making it possible to recover for use substantially all of the coal which such a coal tank holds.

A tender of great coal capacity both as to cross sectional dimensions and longitudinal dimension is desirable for high capacity coal burning locomotives which are to operate with infrequent stoppage for coaling.

While the clearance limitations and optimum overall length of the tank determine the maximum available carrying capacity, it is necessary that means be provided to facilitate loading of the space to its fullest extent, and secondly, provide for withdrawal of substantially all of the coal, for optimum effectiveness of the tender.

These requirements have not been met by prior art tenders which customarily utilize only a portion of the available cross-section space of the tender, because of inclined hopper walls, and which usually require moving of the locomotive along the track beneath a loading chute if the maximum fill is to be attained.

The present invention involves a tender having an elongated coal storage space of substantially rectangular cross-section provided with means whereby it can be filled to a uniform height throughout its length from a single coal receiving zone. This means comprises longitudinal coal transfer devices, and trimming conveyors of the screw type.

The present invention also provides for the utilization of substantially the entire capacity of the storage space and its discharge from the storage space to fuel utilizing apparatus such as a stoker or coal pulverizer, through a coordinated system of coal gathering and coal discharge feed conveyors, which in the present instance are of the helical screw type.

The invention also provides apparatus which has inherent self-governing characteristics as regards the operation of the coal gathering screws, so that coal in the storage space will be made available to the coal feeder screws which operate in coordination with the fuel consuming apparatus.

The apparatus provides a coal supply zone adaptable to a locomotive tender and having an overall length in excess of 40 feet, a transverse

2

width of 8 feet, and a height extending from the frame to the maximum permissible by limiting railway clearances, with storage capacity equal to the contents of a fifty ton railway car.

The coal storage structure is arranged to be sealed so that it may be operated at super atmospheric pressures, and with coal charging and coal discharge apparatus which will insure such sizing of coal that clogging by lumps or wet coal will be avoided, eliminating necessity of any manual work within the storage bin, in normal road operation. Such difficulties are of more importance where the internal dimensions of the bin are such as to provide maximum capacity.

More specifically, the invention involves a bin feeder adapted to deliver coal from the lower part of a coal bin, and so constructed and arranged as to reliably deliver the coal to a point of discharge under conditions which may, at times impose such resistance to the movement of the coal through the feeder that driving mechanisms therefor including prime movers such as electric motors substantially require such driven components as friction clutches which are automatically releasable upon a predetermined overload. The use of such components not only involves additional original expense and increased maintenance, but it also does not promote reliability of operation of the feeder.

It is one object of the invention to provide a bin feeder so constructed and arranged that, if the resistance offered by the coal to the feeder mechanism reaches a predetermined high value, the prime mover will instantly cease operation, but will remain in such condition that it instantly resumes operation when that flow resistance decreases below another predetermined value. The invention also involves an arrangement of prime mover and driving mechanism whereby the prime mover will not be injured or damaged to any extent by the period of inaction during the period of increased flow resistance offered by the coal.

Still more specifically, the invention involves a helical or spiral conveyor in the lower part of the coal bin and arranged to be driven by a steam engine utilizing steam at such a pressure that the engine will automatically cease operation upon a predetermined increase of coal flow resistance, remain in operative condition without damage during the period of inaction, and immediately resume operation upon the decrease of that flow resistance below a predetermined lower value.

The invention also involves a coal bin having

an inlet for the loading of the bin at periodic intervals, this inlet being associated with load trimming devices which promote the uniform loading of the bin with coal and also decrease the time required for loading.

The invention further associates with the bin loading inlet and the associated trimming mechanism, a coal breaker which not only prevents coal units of excessive size from entering the bin, but breaks up those units to such smaller sizes that they are usable by the feeder and by the coal firing system to which the feeder may discharge.

The invention will be described with reference to the accompanying drawings in which an embodiment of the invention is illustrated, and other objects of the invention will appear as the description proceeds.

In the drawings:

Fig. 1 is a vertical longitudinal section of the illustrative bin with bin feeder, trimmer, and breaking mechanism operatively associated therewith;

Fig. 2 is a plan section on line 2—2 of Fig. 1;

Fig. 3 is an outside plan with the hatch cover withdrawn from the loading opening, and indicating the coal trimming apparatus;

Fig. 4 is a vertical section on the line 4—4 of Fig. 1; and

Fig. 5 is a vertical section on the line 5—5 of Fig. 1, showing the arrangement of the coal or elevating conveyors for delivering coal to a pulverizer and associated with the remaining parts of the bin feeder.

The coal bin 10 as indicated by the drawings is of such dimensions that it meets the dimensional limitations involved in its use on a locomotive tender. The floor 12 is arranged for mounting directly on the tender frame or may be formed by a closed frame. Sidewalls 13 and 15, end walls 42 and 72 and the curved deck 17 complete the enclosure of the storage space. As indicated by dot-dash lines in Figs. 4 and 5, space within clearance limitations is provided longitudinally of the bin as a passageway 19.

The deck 17 is provided with two openings 41 and 43. The coal loading opening 41 is arranged with a hatch cover 102 movable by an air cylinder 125 and carried on rollers 104 and 106, while opening 43 is normally closed with a flanged closure as indicated at 47. Both of these closures are of a type which can be sealed so that the coal storage space may be operable under superatmospheric pressure. In this respect a flexible tubular inflatable gasket 49 is provided to seal the space between the hatch cover 102 and the frame surrounding the opening 41 when the hatch cover is positioned in the closing position indicated in Figs. 1 and 4.

With the hatch cover 102 in a retracted position indicated by the dotted lines at 51 in Fig. 3, coal may be spouted from an overhead supply source through the opening 41. A pair of coal trimming screw conveyors extend longitudinally of the bin from the opening 41 to the opposite end of the bin, being located close to the inner face of the top deck. The screws are positioned by the shaft bearings 57 and 59 at the forward driving end, by a hold-down bearings such as 200 adjacent the opposite end of the opening 41 and by cylindrical support sleeves 120, 120', 121, 121', 122, and 122' at the longitudinally spaced positions indicated.

Where the trimming screws extend beneath the charging opening 41, the space is hopped

by longitudinally extending plates (such as 201—204) except for a portion of the lower periphery of each screw in which groups of longitudinal extending bars 130—137 are arranged in spaced relationship to act as a bar screen to limit the size of coal lumps which may be discharged through the screws to the subjacent space.

Groups of crusher teeth 140—145 extend from the rearward end wall of the hopped space in a direction oblique to the axes of the screws so that excessively large coal lumps carried rearward by the rotating screws as they act to advance coal through their respective orifices in the wall will be subjected to a crushing action between the teeth and the driving edge of a screw.

The trimming screws 112 and 114 are arranged to be operatively driven by a power source such as motor 115 through chain 116, sprocket 117 and interconnecting gears 118, the screws being oppositely pitched and rotatable in opposite directions.

With the above described arrangement of a single charging opening and the related trimming apparatus, coal as received through the opening may be distributed longitudinally of the bin so that it may be filled to a height substantially at screw level throughout their length.

When the bin is fully charged, other apparatus coordinated in its operation with the fuel utilizing pulverizer is arranged to withdraw coal from the bin and feed it to the pulverizer in accordance with fuel demands. Uninterrupted coal feed is most desirable, particularly where pulverized fuel firing of locomotives used inasmuch as the storage of pulverized fuel within the pulverized fuel system may not be sufficient to operate at high rates for any but a limited period of time. Accordingly, the coal feeders and supplementary coal recovery conveyor associated therewith are arranged in a manner to insure feed of coal to the pulverizer down to a relatively small residual quantity in the bin. The bottom of the bin is arranged with a transverse recess 42, having a removable cleanout door 210 along a portion of its inclined bottom. Inclined feeder screws 14 and 16 extend from a position in the recess below the level of the bottom 12, where they are carried by bearings 89, through the rear wall 72 at a position adjacent the top of the bin. The shafts extend through an air pressure sealing chamber and bearing structure 220 to complementary sets of driving bevel gears 86, 88, the latter receiving power from a motor which also drives a rotating pressure sealing feeder 90 to which the screws discharge. The feeder screws and the sealing feeder 90 are driven at a rate determined by the coal requirements of the pressure type pulverizer 94 to which the rotary feeder discharges through conduit 92.

The feeder screws are encased in tubes 14' and 16' extending from an elevation near the bottom to an elevation near the top whence a bottom sector 226 extends to the wall 72.

To insure the coal submergence of the lower ends of the feeder screws 14 and 16, two groups of screw conveyors are arranged across the bottom of the bin and are operable to move coal from longitudinally spaced zones of the bin to the central transverse recess 40. Such groups are shown as 18 to 22 and 60—64, the parallel screws of each group operating in concave troughs between which longitudinally extending cricket

structures extend to the height of the axes of the screws. The screws of the respective groups are held in their operative positions in their respective troughs by spaced top embracing guides such as 32-36 or 66-69.

The screws 18-22 are driven from the forward end where their shafts extend through an air seal chamber 230 and are connected by gearing and a chain drive to driving means such as a steam engine 44. Screws 60-64 at the rear end of the bin are correspondingly driven by an engine 74 through similar power transmitting devices. The direction of rotation of the two groups will be in opposite directions inasmuch as they are similarly pitched and it is desired that they act to move coal toward the central recess portion of the bin bottom.

When the bin is full of coal and a considerable gravitational load due to the weight of the coal is exerted downward on the discharge end portions of the screws 18-22 and 60-64, the power to drive the screws is very high; on the other hand, when, through the operation of screws 14 and 16, a considerable quantity of coal is withdrawn from the central portion of the bin above those screws at their lower ends, the height of the coal above screws 18-22 and 60-64 over the discharge end portions of their lengths will be reduced and the pressure against the discharge end portions of the screws which must be overcome, will be reduced.

In the operation of the pusher screws 18-22 and 60-64 the steam supplies to their respective engines are throttled down to such a degree that the engines will stall when the coal over the receiving or lower end of the feed screws 14 and 15 is at a height in excess of a predetermined value, for example three feet. While the steam supply of a predetermined maximum pressure, controlled by a pressure reducing valve 220 is continuously supplied to the engines a constant torque will be exerted on their respective screw drive assemblies but will be counter-balanced by the resistance of the head of coal in excess of the predetermined value. When the feeder screws 14 and 15 then remove coal from the central portion of the bin, the height of coal will be reduced to a value at which the screws will offer insufficient resistance to the engine torque and the engine will automatically start and continue to operate until the coal level at the central zone will reach a height to develop a torque resistance which will stall the engine.

During a period in which the feed screws 18 to 22 and 60-64 are inoperative, the inclined conveyors 14 withdraw material from the transverse hopper or zone 40 until the level of material is reduced to a predetermined extent, for example, three feet above the bottom of the bin. Thereupon, the resistance of the load to the rotation of the above indicated conveyors has decreased to such an extent that the conveyors automatically begin operation. During their operation, they deliver material to the zone 40 at a rate greater than the rate of removal of the material by the inclined conveyors, and this action causes material to pile up to a greater height in and above the zone 40. This action continues until the increased depth of the material again causes the conveyors 18 to 22 and 60 to 64 to cease operation.

The above described cycle of operation is automatic when the bin is filled to a height developing the engine torque resistance in the screw assemblies. When the coal height is lowered still further the engines are operable at slow speed to push the coal to the coal receiving ends of screws

14 and 16 until substantially the entire contents have been removed if not replenished.

It will be apparent that the steam engine is not the only powering means for the screws 18-22 and 60-64 having the desirable torque characteristics, and it is within the concept that constant torque motors may be so used.

Thus in the proposed set-up it is contemplated that with a bin having a full or a substantial charge of coal, the coal feeders 14 and 15 will operate continuously at variable rates of feed in accordance with the pulverizer demands, while the operation of the screws 18-22 and 60-64 will be intermittent in accordance with a predetermined requirement of a head of coal over the coal receiving ends of feeder screws 14 and 16.

While in accordance with the provisions of the statutes we have illustrated and described herein the best form of our invention now known to us, those skilled in the art will understand that changes may be made in the form of the invention covered by our claims, and that certain features of our invention may sometimes be used to advantage without a corresponding use of other features.

What is claimed is:

1. In a material bin and its associated material handling devices, power operated conveyor means for withdrawing material from a receiving position adjacent the bottom of the bin, second conveyor means feeding material from one end of the bin along its bottom to said receiving position, and powering means operating the second conveyor means with a continuous torque of a value sufficient to operate the second conveyor means when the height of the material over the discharge ends of the second conveyor means is reduced below a predetermined value but insufficient to operate said second conveyor means when the depth of the material at the said receiving position and over the discharge portion of the second conveyor means is above a predetermined value, the powering means exerting a continuous torque on the second conveyor means even when said conveyor means is motionless.

2. In material handling mechanism, means removing material from a supply zone, and other means including a continuous torque prime mover and conveyor element normally operating beneath a stratum of the material to move material from the stratum to the supply zone at a rate greater than the rate of removal from said zone by said first means, said conveyor element being subject to a weight of the material upon it and subject to automatic cessation of its operation when that weight of material exceeds a predetermined value, said other means also being automatically operative when the weight of the material above it is reduced below a predetermined value.

3. In a locomotive tender coal bin and its associated coal handling equipment, means forming a hopper extending transversely of the floor of the bin at a position intermediate its length, a plurality of pusher screws arranged longitudinally of the bin at its floor with their discharge ends adjacent said hopper, a constant torque driving means for said pusher screws, said last named means operating the screws at a torque value sufficient to cause the screws to be inoperative when the height of the coal above the discharge ends of the screws is above a predetermined value and sufficient to automatically resume the operation of the screws when that

height of the coal falls below a predetermined value, inclined conveyor means normally feeding coal from said hopper to an elevated discharge position at one end of the bin, and a loading hatch at the top of the bin.

4. In a railway car body and its associated material handling devices; the car body having sides, ends and bottom providing a material containing chamber; power operated conveyor means having its inlet or supply end disposed beneath a material receiving position adjacent the bottom of the car body; second conveyor means normally feeding material from both ends of the car body to said receiving position, said second conveyor means including a front group of conveyors moving material from one end of the car body toward said receiving position and a rear group of conveyors moving material from the opposite end of the car body to said receiving position; the receiving position between and above the discharge ends of the groups of conveyors being free from structural obstructions; a first low pressure steam engine driving the first group of conveyors from one end of the car body; and a second low pressure steam engine driving the second group of the conveyors from the opposite end of the car body; the low steam pressure for the engines being of a value sufficient to operate the group conveyors when the height of material over the discharge ends of the group con-

veyors is reduced below a certain value but insufficient to operate the group conveyors when the depth of the material at the receiving position and over the discharge ends of the group conveyors is greater than said certain value.

5. The combination of claim 4 further characterized by the provision of a longitudinal attendant's closed passageway leading longitudinally of the car body from the first steam engine to the second and disposed within the transverse clearance limitations of the car body.

#### References Cited in the file of this patent

##### UNITED STATES PATENTS

Number	Name	Date
1,404,985	Lower	Jan. 31, 1922
1,606,228	Hunt	Nov. 9, 1926
1,856,572	Lower et al.	May 3, 1932
1,889,562	Moulthrop	Nov. 29, 1932
1,915,757	Pierce	June 27, 1933
1,915,758	Pierce	June 27, 1933
2,029,295	Anderson	Feb. 4, 1936
2,029,296	Harrison	Feb. 4, 1936
2,066,756	Anderson	Jan. 5, 1937
2,080,710	Hansen	May 18, 1937
2,141,920	Lenhart	Dec. 27, 1938
2,190,724	McBride	Feb. 20, 1940
2,237,428	Hanna	Apr. 8, 1941
2,285,236	Van Etten	June 2, 1942